

### EDITOR IN CHIEF

*Dr. R.V.D Rama Rao*

Professor & HOD-EEE

### EXECUTIVE EDITOR

*Dr. S. Pragaspathy*

Associate Professor-EEE

### ASSOCIATE EDITORS

*Mr. P. Naveen*

Associate Professor - EEE

*Mr. B.N. Ch.V. Chakravarthi*

Associate Professor - EEE

### STUDENT CO-ORDINATORS

Durgesh – II Year

Deepak - II Year



08816 - 251333



08816 - 250344



hod\_eee@vishnu.edu.in



# VISHNU INSTITUTE OF TECHNOLOGY

(Approved by A.I.C.T.E. & Affiliated to J.N.T.U Kakinada)

Vishnupur, BHIMAVARAM – 534 202

**Department of Electrical & Electronics Engineering**

## **VISION AND MISSION OF THE DEPARTMENT**

### **VISION:**

To be recognized as a Centre of Excellence in the field of Education and Research so as to produce Competent & Ethical Engineers capable enough to contribute to the society.

### **MISSION:**

- To develop innovative, efficient and proficient electrical engineers.
- To keep the curriculum industry friendly, with due regard to the University curriculum.
- To be a place for innovative blended learning and entrepreneurship development in multidisciplinary areas.
- To promote ethical and moral values among the students so as to make them emerge as responsible professionals.

## **PROGRAM EDUCATIONAL OBJECTIVES (PEO's)**

- PEO1:** To produce Electrical and Electronics Engineering graduates who have strong foundation in Mathematics, Sciences and Basic Engineering
- PEO2:** To provide intensive training in problem solving, laboratory skills and design skills to use modern engineering tools through higher education and research.
- PEO3:** Ability to pursue higher studies and to seek employment in a variety of engineering technology positions and work successfully in their chosen career aspirations and generate entrepreneurs.
- PEO4:** To inculcate in students professional and ethical attitude, effective communication skills, teamwork skills, multidisciplinary approach, and an ability to relate engineering issues to broader social context through life-long learning.

# INDEX

S.NO	PROJECT	P.NO
<b>1.</b>	POWER QUALITY IMPROVEMENT OF DISTRIBUTED SYSTEM WITH HYBRID RENEWABLE ENERGY FARM USING UPQC	<b>1-3</b>
<b>2.</b>	MITIGATION OF UNCERTAINTIES IN HYBRID RENEWABLE ENERGY	<b>4-5</b>
<b>3.</b>	ANTI-ISLANDING PROTECTION OF A MICROGRID USING DWT	<b>6-8</b>
<b>4.</b>	STAR-DELTA STARTER AND MONITORING OF THREE PHASE INDUCTION MOTOR PARAMETERS BY USING PLC AND HMI	<b>9-11</b>
<b>5.</b>	FORWARD AND REVERSE OPERATION AND MONITORING OF 3-PHASE I.M PARAMETERS BY USING VFD, PLC AND HMI	<b>12-13</b>

# 1. POWER QUALITY IMPROVEMENT OF DISTRIBUTED SYSTEM WITH HYBRID RENEWABLE ENERGY FARM USING UPQC

P.PRASANTH, P.SUNIL BABU, S.MANIKANTA, S.NAGA SRINIVAS,  
K.SIVA SHANKAR.

**SUPERVISOR: Mr. Ch. PHANI KUMAR, M. Tech.**

## **Objective of the project:**

This paper describes the power quality improvement of the integrated distributed system of solar photo-voltaic-wind energy hybrid renewable energy farm grids using a Unified Power Quality Controller/regulator (UPQC). The hybrid system includes a renewable energy farm, to support the photovoltaic energy generation system and wind energy conversion system. UPQC consists of two active power filters that are shunt APF and series APF. The control schemes used are the Hysteresis voltage controller by using a-b-c to d-q transformation and hysteresis current controller using p-q theory in shunt APF and series APF respectively, the system perceptible frequent disturbances in AC loads and output power from the renewable farm. These problems can be removed by using an adjustable reactive power source i.e. Unified power quality Controller/regulator (UPQC). UPQC has to improve power quality like compensating the harmonic current, reactive power; voltage imbalance, Sag and Swell. UPQC also helps in dropping energy losses that happen in power systems components and also increases safety. In this paper, it is shown via MATLAB simulation how the UPQC model can be used to reduce the % THD in source voltage, source current and load voltage waveforms created due to non-linear/sensitive loads usage.

## Proposed block diagram:

1

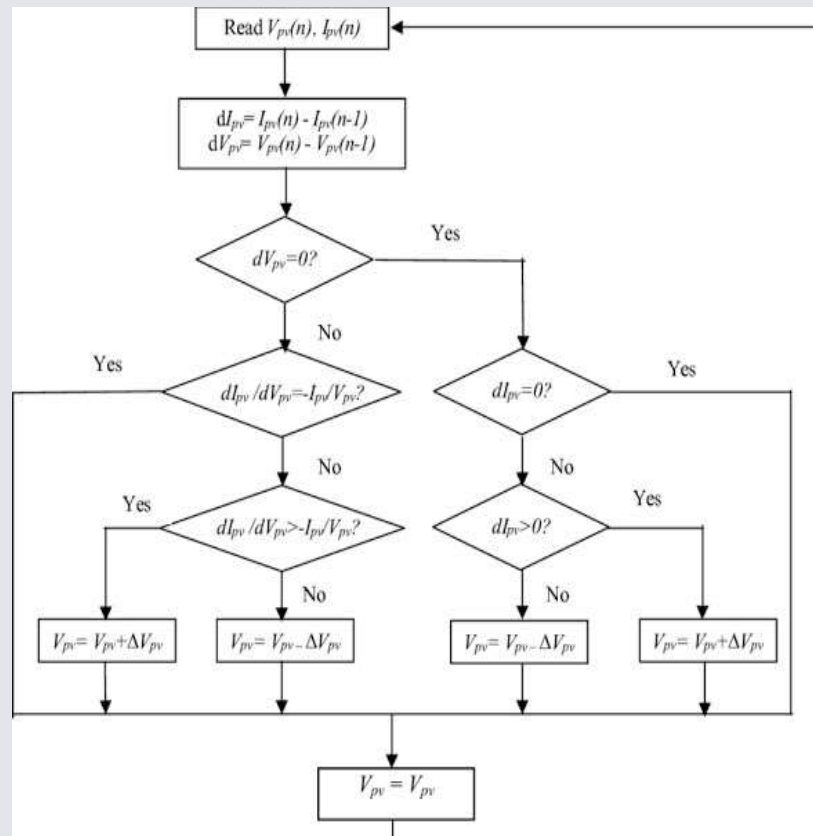

## Module(s) of the prototype:

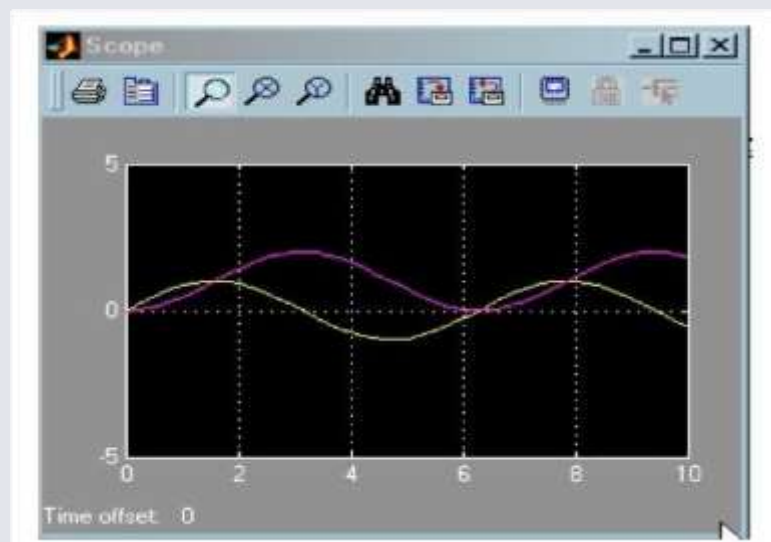

Sine wave form generate in matlab

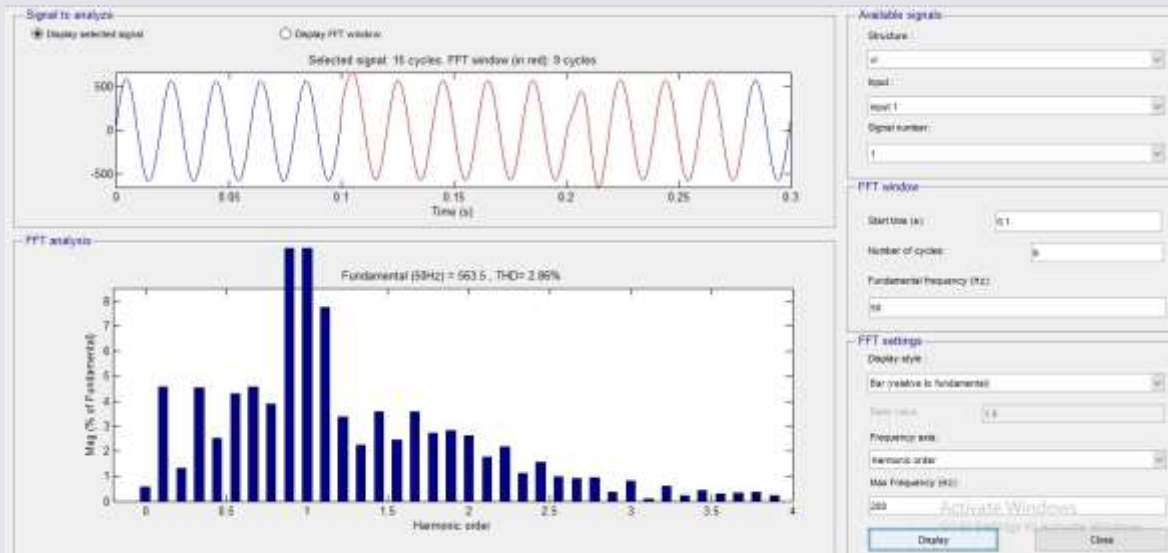

Total harmonic distortion Analyzer

## **CONCLUSION:**

This paper represents power quality improvement in grid in graded distributed system with hybrid renewable energy system using UPQC by fuzzy controller. In this process hybrid system formed by combination of Solar PV generation system and wind energy conversion system, and controlled by MPPT technique. A FACT control device is UPQC is used for improving power quality in distributed system like compensating the harmonic current, reactive power, voltage imbalance, voltage sag and swell. Upqc consists of shunt converter and series converter connected back to back and these converters are controlled by abc to do transformation technique. Shunt part of UPQC removes all the current related harmonic problems in the system and series connected APF of UPQC system removes all voltage harmonics which comes up due to the use of nonlinear load. The overall THD is now improved in the system which is clearly observed from the FFT analysis. Preventing the harmonics due to presence of nonlinear load is difficult but its controlling is possible and many research works is still going on for the same.

## 2. MITIGATION OF UNCERTAINTIES IN HYBRID RENEWABLE ENERGY SYSTEMS

P.P.V.KRISHNA TEJA P.HEMANTH KUMAR P.T.LAKSHMI RAMYAS.

TARUN SANKAR

SUPERVISOR: Dr. S. PRAGASPATHY, M.E., Ph.D.,

### Objective of the project:

Electricity is very important facility for the human being. All the convectional energy resource are changing day by day. So it is necessary to shift from convectional to nonconventional energy resources. Although solar and wind energy are two of the most viable renewable sources. Little research has been done on operating both energy sources along the side one another in order to take the advantage of their complementary characters. In this content autonomous photovoltaic and wind hybrid energy systems have been found to be more economically viable alternative to full fill the energy demands of numerous isolated consumers' world side. In this project, an optimal design of a hybrid solar-wind energy plant is developed with different ideas of the hybrid system configuration with appropriate exercising of power with respect to source, load and battery. This project also observes and identify the different hybrid renewable system and then identify the uncertainties caused by it and overcome that uncertainties.

### Proposed block diagram:

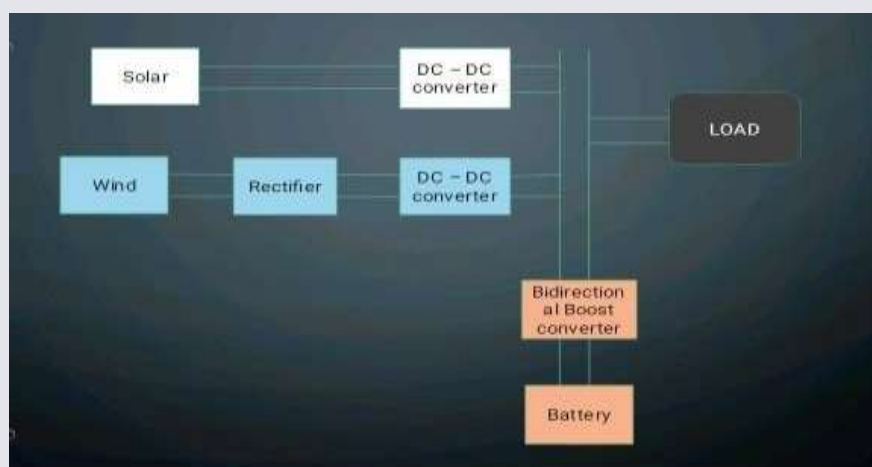

Proposed Solar Wind Hybrid System

## Module(s) of the prototype:



A Multi-Bladed Wind Turbine

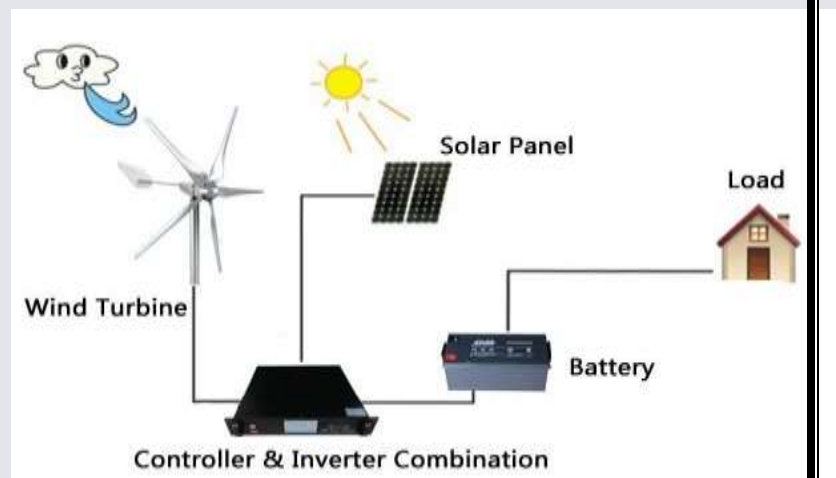

Hybrid System

## **CONCLUSION**

The utilization of renewable resources is greatly demanding in the world. The world facing the problem of global scarcity of electricity and pollution can be easily overcome with renewable energies. The presented research work is based on the different researches on the utilization of the natural resources like solar and wind and combination of both the sources. Hybrid power generation is the solution to compensate the upcoming demand. In this project an optimal design of a hybrid solar wind energy plant is developed with different ideas of the hybrid system configuration with appropriate exercising of power with respect to source, load and battery.



### 3. ANTI-ISLANDING PROTECTION OF A MICROGRID USING DWT

S.VENKAT SAI CHARAN, P.YEZRA, K.VAMSI, S.RAGHU RAM  
SUPERVISOR: Dr.B.MALLIKARJUNA, PhD

#### Objective of the project:

To enhance the reliability of the power supply, preventing unwanted islanding of micro grids is utmost important. In this project, we are proposing a methodology to prevent unwanted islanding of micro grids using **Discrete Wavelet Transform with Multi-Resolution Analysis (MRA) technique**. The detailed coefficients are used for implementing the proposed methodology. These coefficients are transferred through do transformation. The standard deviation of q-axis, q-axis and o-axis components are estimated. The do transformed detail coefficient signals are used because these values are more accurate than that of raw signals (three-phase current signals).

A disturbance condition, if the maximum value of standard deviation of any one of d-axis or q-axis or o-axis is greater than the threshold value. Otherwise, the prevailing condition is normal. When a disturbance condition is detected, the proposed methodology checks if the deviation in power is greater than the normal value for 0.1 sec. If it is so, the proposed methodology prevents unwanted operation of the breaker, thereby unwanted islanding of the micro grid is prevented.

To verify the performance of the proposed methodology, a test system of main grid integrated with a solar energy source is considered and implemented in the **MATLAB/Simulink** environment. Numerous case studies are carried out on the system. The results show the reliable performance of the proposed anti-islanding protection methodology. From the result analysis, it can be observed that the proposed methodology prevents unwanted islanding of micro grids. In other words, it provides anti-islanding protection to the micro grid.

## Proposed block diagram:

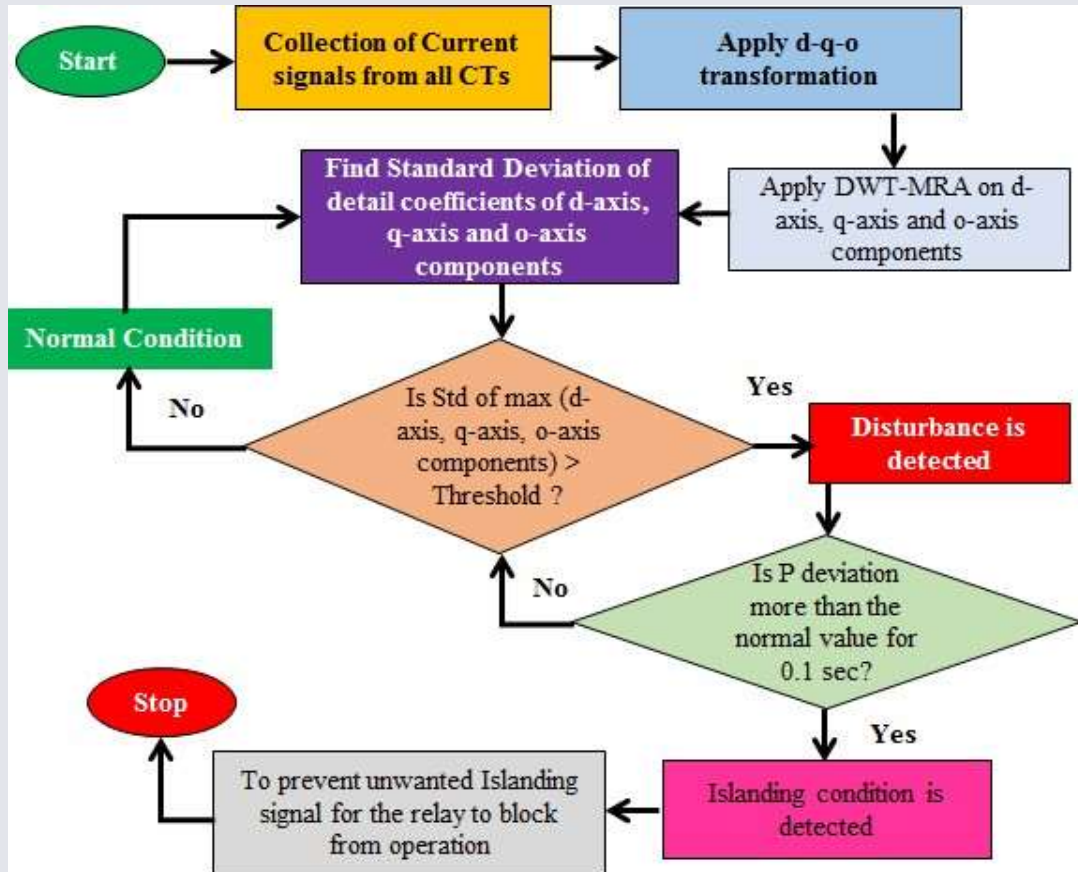

## Module(s) of the prototype:

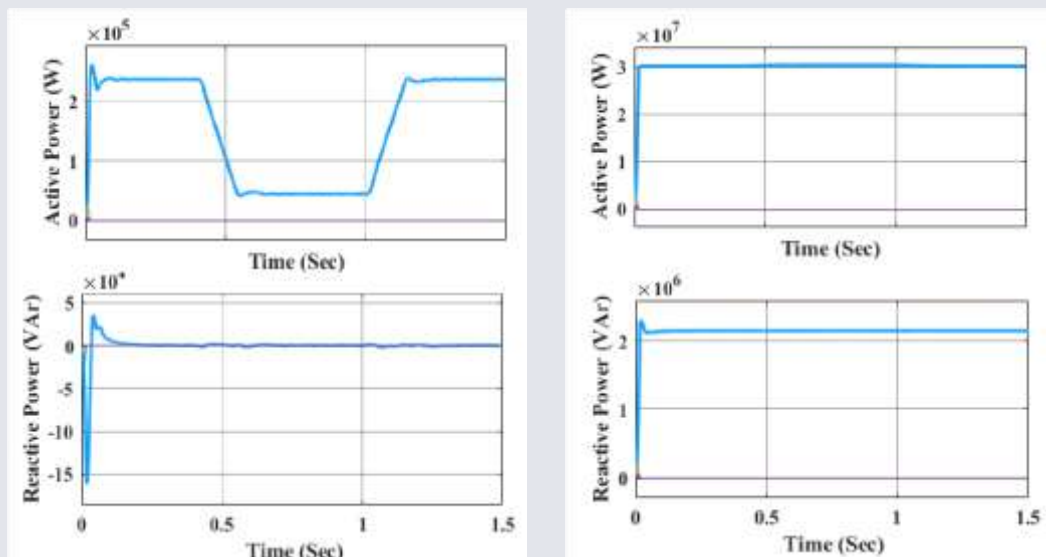

Active and Reactive power at Bus-1 (b) Active Power & Reactive Power at Bus-1 after addition of Load at 8 km from Bus-1.

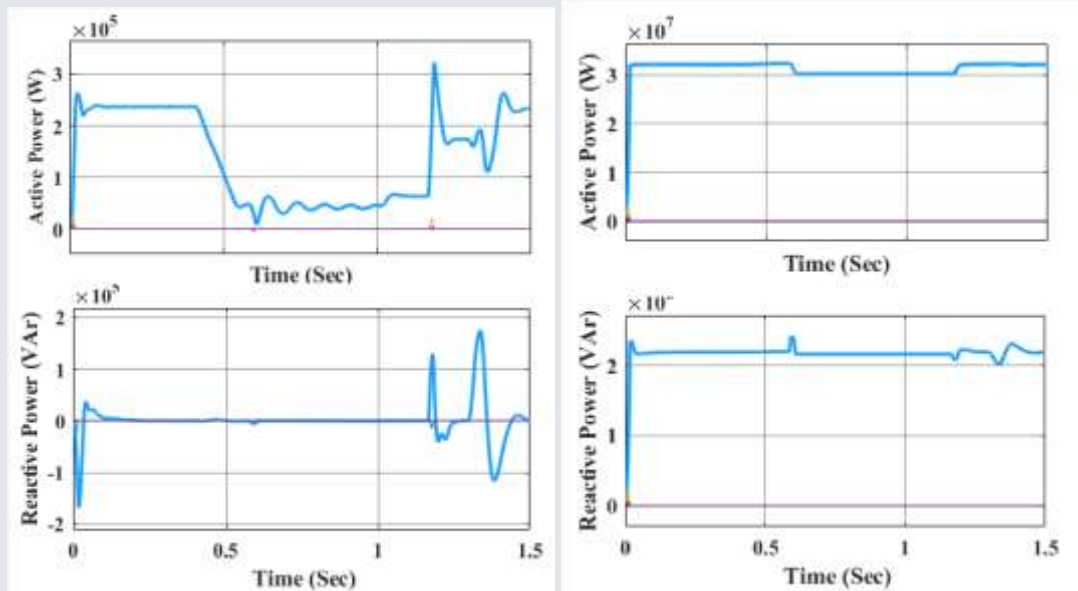

Active and Reactive power at Bus-1 (b) Active Power & Reactive Power at Bus-1 after without Preventing breaker mal-operation.

## CONCLUSION

As per the case study it is clear that the discrete wavelet transforms with multi-resolution analysis can detect the faults at any level of the whole grid. In this way, it helps us in the improvement of the protection of the micro grid. The designed algorithm determines the prevailing condition using the standard deviation of detail coefficients of d-axis, q-axis and o-axis components with the stated threshold values. The threshold value selected from the normal condition of the system. It is 0.1378. If the power deviation is more than the normal values for 0.1 sec, the proposed methodology prevents unwanted operation of the circuit breakers at PCC. In other words, the proposed methodology prevents unwanted islanding of micro grids. If such a condition does not occur, the proposed methodology supervises the operation of the relays..

The case studies considered to test the efficacy and performance of the proposed methodology are also discussed. The results show that the proposed method can prevent unwanted micro grid islanding due to various reasons while preserving the security of the system.

## **4. STAR-DELTA STARTER AND MONITORING OF THREE PHASE INDUCTION MOTOR PARAMETERS BY USING PLC AND HMI**

OGIRALA SOWJANYA, DODDAVARAPU SUBRAMANYAM, PEDAPATI  
BALARAM SANDEEP, SANKU SREE PHANI KUMAR

**SUPERVISOR:** Mr.B.Swamy, M.Tech

### **OBJECTIVE OF THE PROJECT:**

Star-Delta starters are the most common reduced voltage starters in the 50 Hz industrial motors. Star-Delta starter is required to start more than 10 HP motor. Main use of this starter is to reduce the starting current. Due to starting star connection reduces the voltage by  $1/\sqrt{3}$  times. Due to this reduced voltage starting current is limited. This is cheap and maintenance free starter. They are used in an attempt to reduce the starting current applied to the motor during start. Due to the wide variety characteristics of the induction motor, it plays the premier role in the industrial sector. It is often used for starting three-phase induction motors, but can only be used when starting the motor without load and when the required starting current is relatively low. In this project, we have physically designed the star-delta starter by using contactors. We have designed to run the three-phase induction motor in both automatically and manually by using PLC (Programmable Logic Controller). Existing monitoring and control of an induction motor systems must be interoperable with next generation products to ensure smart integration in order to update existing system by reducing the cost and increasing the reliability. The best method must be chosen for efficient use of energy in some cases such as speed control, switching-on or switching-off, or in controlling the speed of induction motors, which make up a large part of the load group in industrial field. In this study, the controlling and monitoring of an induction motor parameters were carried out over a computer by using the Profibus (Process Field Bus) communication method through the TIA (Totally Integrated Automation) Portal program used to program all Siemens PLCs (Programmable Logic Controllers).

## PROPOSED BLOCK DIGRAM:

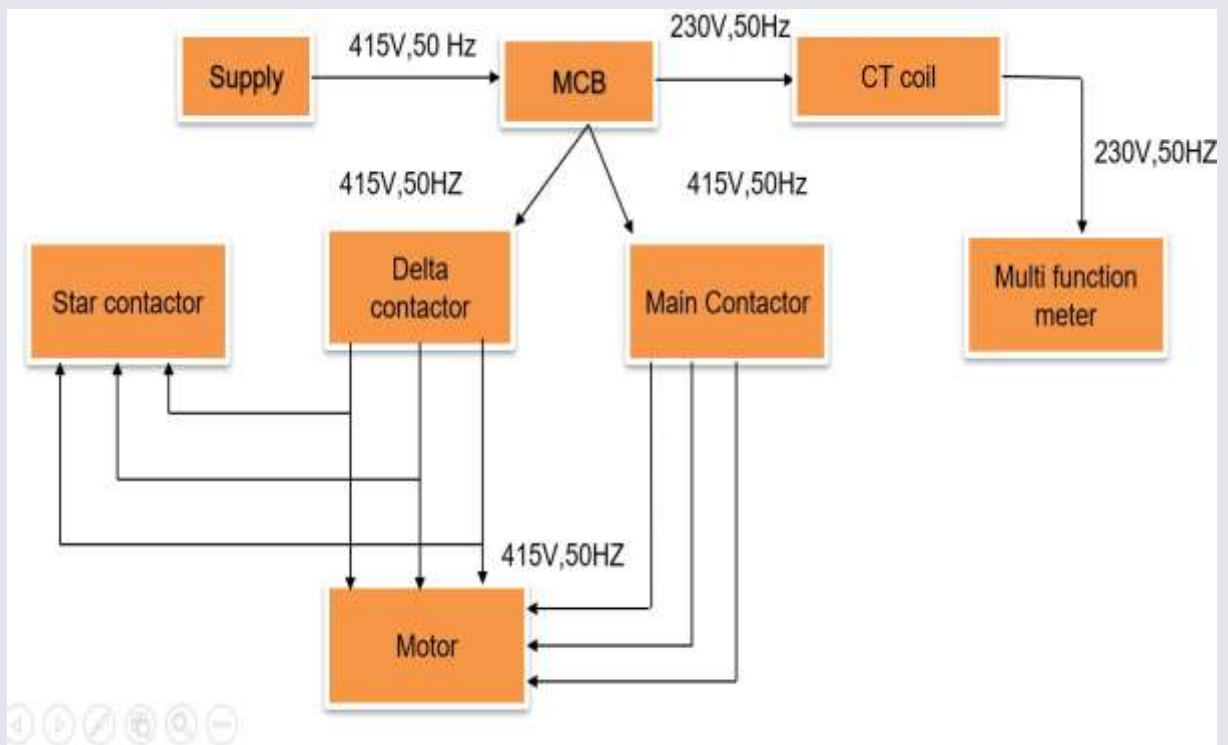

## POWER WIRING

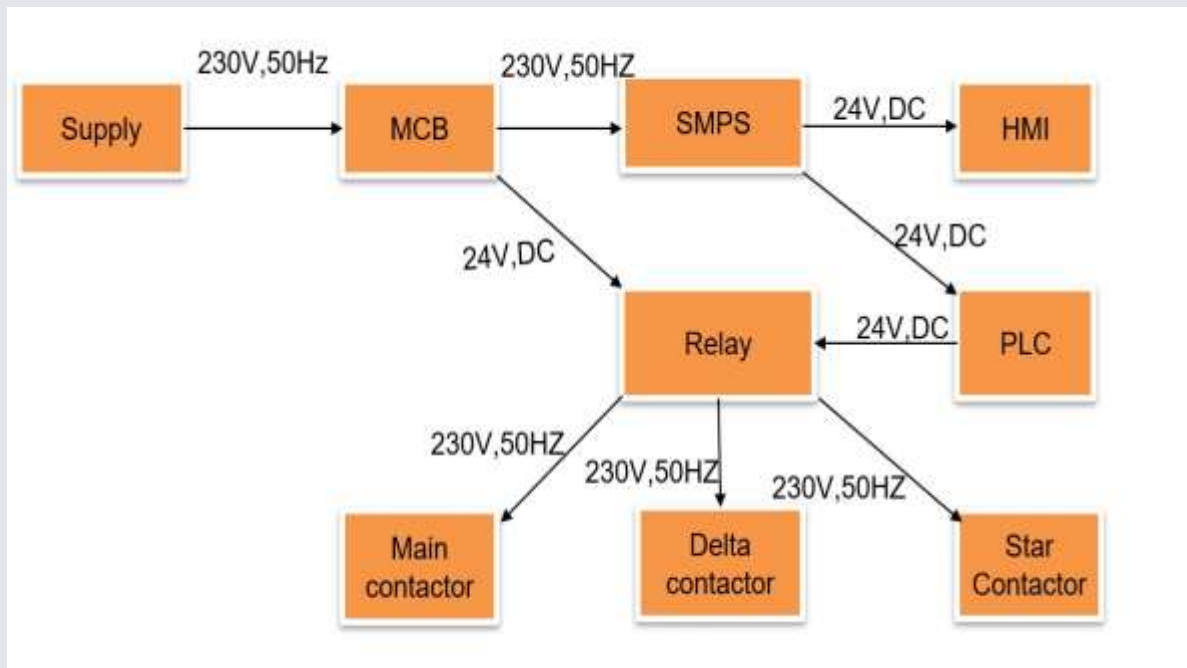

## CONTROL WIRING

## **MODELE(S) OF THE PROTOTYPE:**



## **CONCLUSION OF THE PROJECT**

With the help of this project, we can give a clear idea about the star- delta starter and monitoring of three phase induction motor parameters by using plc and HMI. Because of the reduction in starting current, starting torque reduces. Therefore, we can conclude that by using Star Delta starter, the starting current is reduced to approximately two thirds.

## 5.FORWARD AND REVERSE OPERATION AND MONITORING OF 3-PHASE I.M PARAMETERS BY USING VFD, PLC AND HMI

SEELAM VINAY KUMAR REDDY, SAMBRANI CHANDANA  
MANIDEEPIKA, SUNKARA CHANDU KUMAR, UPPULURI CHANDU  
**SUPERVISOR: Dr. IDAMAKANTI KASIREDDY, Ph.D.**

### **OBJECTIVE OF THE PROJECT:**

Forward and Reverse operation is required in manufacturing industry and it is very important to monitor every parameter in the industry where the number of heavy motors and equipment's are connected. Problem identified: Windings are under huge load and Smooth operation is difficult to achieve. This can be done by PLC (Programmable Logic Controller), VFD (Variable Frequency Drive), and HMI (Human-Machine Interface). In this project real time industrial implementation of Forward and reverse operation of 3 phase induction motor, monitoring and control of all electrical parameters has been done using PLC, VFD and HMI.

### **PROPOSED BLOCK DIAGRAM:**

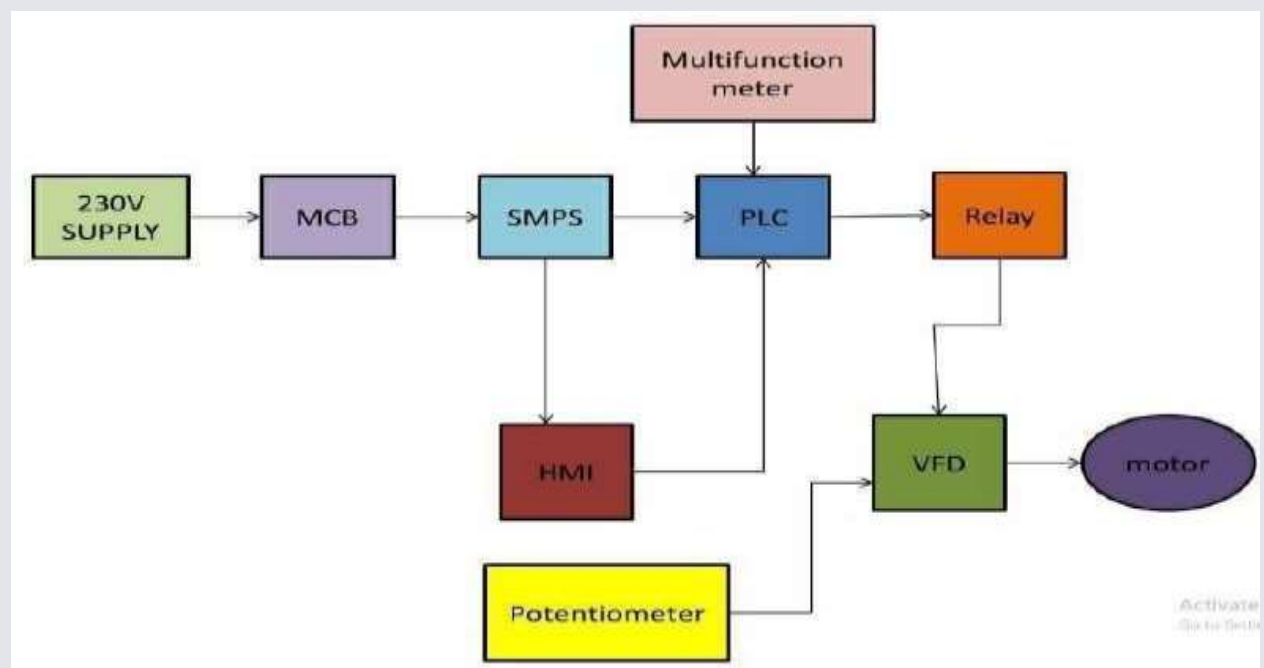

Block Diagram

## **MODULE(S) OF THE PROTOTYPE:**



FRONT VIEW



INSIDE VIEW

## **CONCLUSION:**

Forward and Reverse operation is required in manufacturing industry and it is very important to monitor every parameter in the industry where the number of heavy motors and equipment's are connected. But it is very difficult to operate in forward and reverse operation. In order to overcome this drawback we did this project. In this forward and reverse operation and monitoring of 3 phase induction motor parameters by using VFD, PLC and HMI we finally get the induction motor parameters in the human machine interface (HMI) front panel and all so we operate the motor in both forward and reverse direction without any sudden change in current and voltage.

In this front panel we get the induction motor parameters like: Current, Voltage, Frequency, Speed, Power, and Line voltages, Line current so finally I can conclude that we done the forward and reverse operation of 3 phase induction motor parameters by using VFD, PLC and HMI.